

# CDL/CDLF200

## Графические характеристики

2950 об/мин

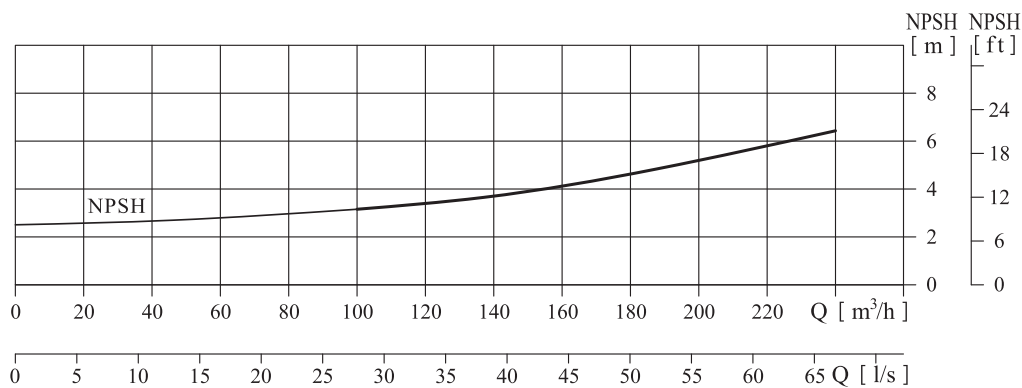
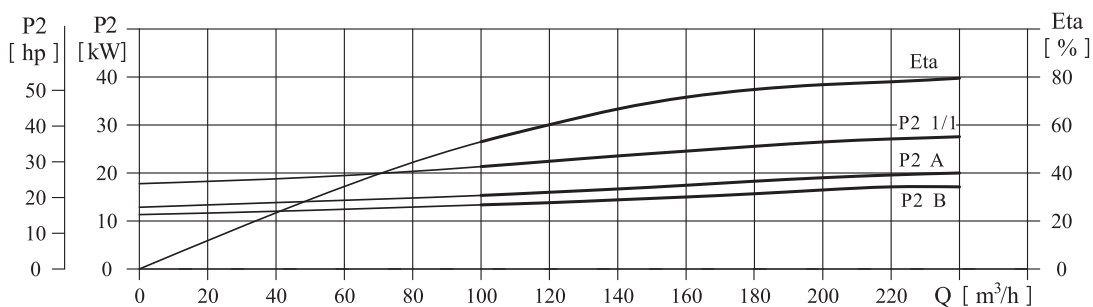
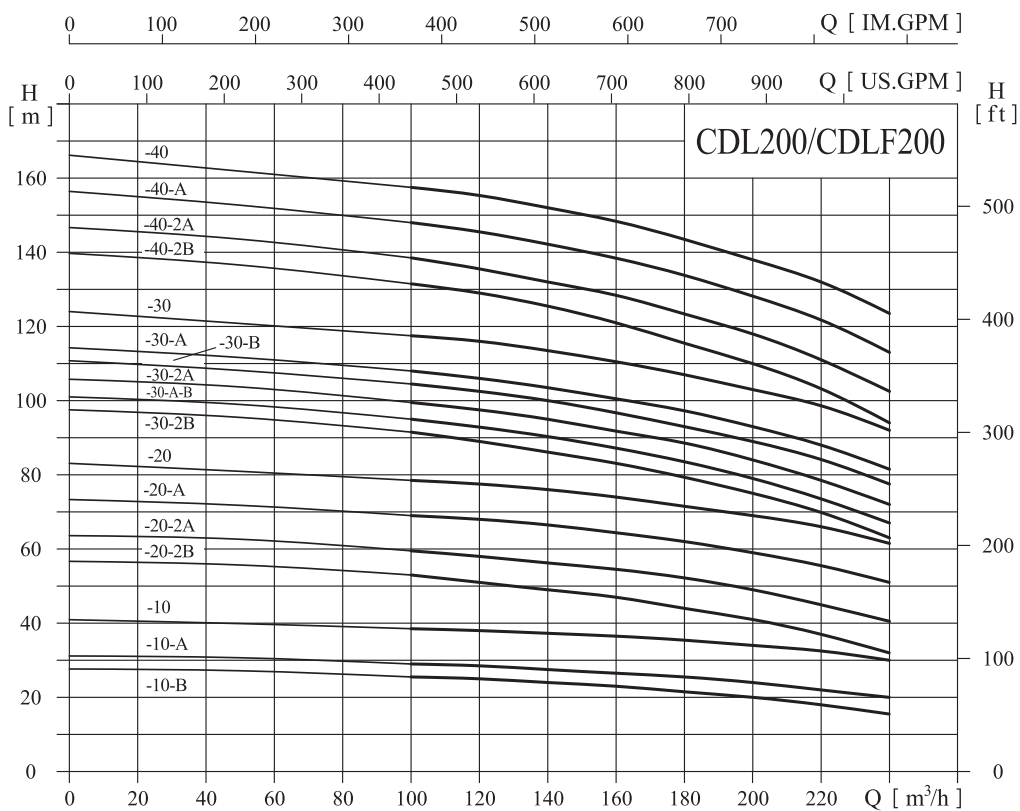

# CDL/CDLF200

## Таблица характеристик

| Модель        | Приводной двигатель |      | Q<br>(m <sup>3</sup> /h) | 100   | 120   | 140   | 160   | 180   | 200 | 220   | 240   |
|---------------|---------------------|------|--------------------------|-------|-------|-------|-------|-------|-----|-------|-------|
|               | (kW)                | (hp) |                          |       |       |       |       |       |     |       |       |
| CDL200-10-B   | 18.5                | 25   | H<br>(m)                 | 25.5  | 25    | 24    | 23    | 21.5  | 20  | 18    | 15.5  |
| CDL200-10-A   | 22                  | 30   |                          | 29    | 28.5  | 27.5  | 26.5  | 25.5  | 24  | 22    | 20    |
| CDL200-10     | 30                  | 40   |                          | 38.5  | 38    | 37.5  | 36.5  | 35    | 34  | 32.5  | 30    |
| CDL200-20-2B  | 37                  | 50   |                          | 53    | 51    | 49    | 47    | 44    | 41  | 37    | 32    |
| CDL200-20-2A  | 45                  | 60   |                          | 59.5  | 58    | 56    | 54    | 52.5  | 49  | 44.5  | 40.5  |
| CDL200-20-A   | 55                  | 75   |                          | 69    | 68    | 66    | 64    | 62    | 59  | 55.5  | 51    |
| CDL200-20     | 55                  | 75   |                          | 78.5  | 77.5  | 76    | 74    | 71.5  | 69  | 66    | 61.5  |
| CDL200-30-2B  | 75                  | 100  |                          | 91.5  | 89    | 86.5  | 83.5  | 79    | 75  | 70    | 63    |
| CDL200-30-A-B | 75                  | 100  |                          | 95    | 93    | 90    | 87    | 83.5  | 79  | 73.5  | 67    |
| CDL200-30-2A  | 75                  | 100  |                          | 99.5  | 97.5  | 94.5  | 91.5  | 89    | 84  | 78.5  | 72    |
| CDL200-30-B   | 75                  | 100  |                          | 104.5 | 102.5 | 100   | 97    | 93    | 89  | 84.5  | 77.5  |
| CDL200-30-A   | 75                  | 100  |                          | 108   | 106   | 103.5 | 100.5 | 97.5  | 93  | 88    | 81.5  |
| CDL200-30     | 90                  | 120  |                          | 117.5 | 116   | 113.5 | 110.5 | 107   | 103 | 99    | 92    |
| CDL200-40-2B  | 90                  | 120  |                          | 131.5 | 129   | 125.5 | 121   | 115.5 | 110 | 103.5 | 94    |
| CDL200-40-2A  | 110                 | 150  |                          | 138.5 | 136   | 132   | 128   | 124   | 118 | 111   | 102.5 |
| CDL200-40-A   | 110                 | 150  |                          | 148   | 145.5 | 142.5 | 138   | 134   | 128 | 122   | 113   |
| CDL200-40     | 110                 | 150  |                          | 157.5 | 155.5 | 152.5 | 148   | 143.5 | 138 | 132.5 | 123.5 |

## Габаритно-присоединительные размеры и масса

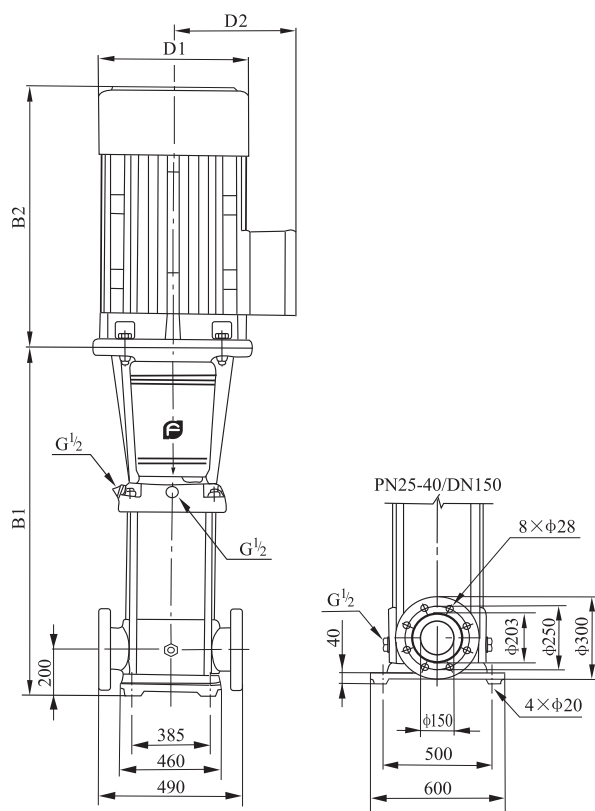

| Модель        | Размер (мм) |      |       |     |     | Масса<br>(кг) |
|---------------|-------------|------|-------|-----|-----|---------------|
|               | B1          | B2   | B1+B2 | D1  | D2  |               |
| CDL200-10-B   | 907         | 550  | 1457  | 330 | 255 | 311           |
| CDL200-10-A   | 907         | 590  | 1497  | 360 | 285 | 347           |
| CDL200-10     | 907         | 660  | 1567  | 400 | 310 | 403           |
| CDL200-20-2B  | 1101        | 660  | 1761  | 400 | 310 | 447           |
| CDL200-20-2A  | 1101        | 700  | 1801  | 460 | 340 | 504           |
| CDL200-20-A   | 1131        | 770  | 1901  | 540 | 370 | 595           |
| CDL200-20     | 1131        | 770  | 1901  | 540 | 370 | 595           |
| CDL200-30-2B  | 1325        | 845  | 2170  | 580 | 410 | 748           |
| CDL200-30-A-B | 1325        | 845  | 2170  | 580 | 410 | 748           |
| CDL200-30-2A  | 1325        | 845  | 2170  | 580 | 410 | 748           |
| CDL200-30-B   | 1325        | 845  | 2170  | 580 | 410 | 748           |
| CDL200-30-A   | 1325        | 845  | 2170  | 580 | 410 | 748           |
| CDL200-30     | 1325        | 895  | 2220  | 580 | 410 | 817           |
| CDL200-40-2B  | 1519        | 895  | 2414  | 580 | 410 | 830           |
| CDL200-40-2A  | 1519        | 1140 | 2659  | 645 | 550 | 1180          |
| CDL200-40-A   | 1519        | 1140 | 2659  | 645 | 550 | 1180          |
| CDL200-40     | 1519        | 1140 | 2659  | 645 | 550 | 1180          |

Габаритные размеры однофазного двигателя и взрывозащищённого электродвигателя имеют небольшие отличия. Пожалуйста, свяжитесь с нами для получения подробной информации.